

# Adding Context Information to Digital Photos

Paul Holleis, Matthias Kranz, Marion Gall, Albrecht Schmidt  
*Research Group Embedded Interaction*  
*University of Munich*  
*Amalienstraße 17*  
*80333 Munich, Germany*  
*{paul, matthias, marion, albrecht}@hcilab.org*

## Abstract

*In a user centered design process, we investigate what context information may be used to augment digital photos with additional meta information. We describe our initial findings from user interviews and present the design and implementation of a prototype that is used to carry out studies with users. The basic prototype is a sensor box attached to a digital camera mounted beneath the camera instead of a tripod and wirelessly connected to a wearable computer. In a study with three professional photographers and two hobbyists we could show the feasibility of this approach. Based on the results gained we suggest potential improvements for digital photography.*

## 1. Introduction

Since the launch of the first digital camera in 1990, the development of digital cameras has tremendously increased its popularity in people's everyday life.

In a photo, a specific view at a particular moment in time is captured. Even with advances in video capturing, a moment captured in an image has not lost its appeal. In many cases new digital photography leads to an increased number of photos taken by individuals.

Current digital photos contain an extensive set of meta information by default. Most cameras offer a way of storing meta information about photos taken; a widespread way is to encode information in the image files. One example is the EXIF format, see [8]. Typical tags that are stored are date and time, camera model, image pixel size and resolution, focal length, exposure time, aperture, and ISO-speed. Some cameras also record information that is directly related to the content. One example is the distance to the captured motive as measured by the camera's autofocus.

Including information about where a photo is taken has been proposed in various projects and several implementations are available. The general approach is to connect a location sensor to a camera. This includes cameras using a GPS receiver [1]. Furthermore, with mobile phones including a digital camera, the position information available in the phone (cell information or a more fine grained estimation) can be used as meta data, too.

Meta information attached to digital images is a rich source for selecting a specific image from a larger archive. Our initial observations showed that many people use meta data, in particular date and if available location, as an important filter when searching for a particular image. Furthermore we could observe that people who told us that they are not adding meta data to their photo collection still add *some* meta data by naming the folders. Typically, meta information can be divided in three categories:

- events (e.g. graduation),
- locations (e.g. London), or
- activities (diving holiday).

Combinations of these categories commonly appear, too. Often, 'activity' or 'event' is combined with 'location' and supplemented with an approximate date (e.g. Skiing St. Moriz 02). This minimal additional amount of information helps people to access their images. So far, meta information has to be manually added.

Based on these observations and our experiences with sensors we investigated how additional meta information can be automatically acquired. In our research we particularly investigate the following two questions:

- What types of meta information may be useful for people when using digital images?
- What sensors can be used to acquire additional meta information?

Based on a user centered design process we explore what information appears to be interesting to people and how it can be acquired in different contexts of use. Our approach has been to explore a range of available sensing technologies that can be of use to produce meaningful meta information. We focused on sensors that are cheaply available and can easily be attached to a camera. In our research we first conducted initial interviews and an online-survey over the WWW (Section 2). Based on these findings we constructed a working prototype for meta data acquisition that can be used together with an ordinary digital camera (Section 3). Using this prototype we performed a study with three professional photographers and two amateurs acquiring over 350 photos in regular shootings with meta information (Section 4). In Section 5 we compare our work to related work in the area of context-aware photography.

## 2. What Users Want

In the early phase of the projects we conducted a small number of interviews with people on the topic of context-aware photography. In particular we were interested what additional information people would like to save with their photos. In these interviews we did not constrain our questions or the answers by technical feasibility. The initial results showed that there is an actual interest in supplementing photos with additional data, including location, activity, environmental information, physiological parameters and information about the current social situation. These interviews lead to a more systematic survey on the topic.

### 2.1. Online Survey

With the survey we wanted to target a wide range of people, from individuals who rarely take photos or only take photos at special events, hobbyists who take photos in very special contexts (e.g. sportive activities), to professional photographers. To achieve this variety, we decided to design an online form and recruit participants via email. The email distribution was started with students that took part in a one-day introduction to digital photography at our department and with the social network of the authors. In the email people were encouraged to forward the mail within their social network.

One goal was to find out what meta information is already in use by people. We were interested in data that is recorded automatically (e.g. the time when a digital photo is taken and the shutter time) as well as additional information that is added manually when the

photos are taken or shortly afterwards (e.g. naming photos or clustering photos into groups and folders). We were interested how people use this information to organize their collections and how meta data adds a substantial value to the pictures themselves.

Based on currently used meta data, we extended this concept in the survey and asked for further information that people considered of interest for them. In particular, we are interested what data could be acquired with sensors that could be included in the camera. Furthermore we questioned people what they would like to use the additional information for and in which situations.

The survey was fully completed by more than 100 participants. The remainder of this section describes the main findings

### 2.2. Contexts of Interest

From the interviews and the survey we conclude that there are at least four main areas of interest in which users could see additional value.

- Handling of the camera  
One important example in this class is basic information about orientation, angles, and position of the camera with respect to the motive.
- Environmental conditions  
Light conditions, in which a shot was taken is one example in this class. In certain usage contexts information about temperature and further environmental conditions is valuable.
- Physiological information  
Physiological information, such as change in galvanic skin response and heartbeat, appear to be of interest in contexts where the person taking the pictures is closely involved in the action captured (e.g. sports, mountain tour).
- Social context  
This is mainly information about other people that are around when a photo is taken or in our study, by observing the test persons.

It also appears that the value of meta data is closely dependent on the context in which the photos are taken. Considering hobbyists who take photos of specific activities and of professionals working in specific areas it is difficult to generalize. In the following section we present certain areas where additional meta information is of use.

### 2.3. Application Domains

Generally it is often assumed that having more meta information is better. But looking at the variety of EXIF information recorded with current cameras we

found that most of the information is hardly ever used. In our enquiries we were interested in concrete application domains where people can see the value of additional meta data. The following areas appear to be important:

- Archive, search, and retrieval  
The obvious domain for using meta information is in the area of archiving, searching, and retrieving specific pictures. Additional information on the context in which a photo was taken can help to search archives for specific photos. This seems to be especially interesting for people with large archives and meaningful contexts.
- Reproducibility of images  
In professional domains, such as photography of machinery, the reproducibility of photos is of interest. With recorded context data, especially on camera handling and environmental conditions, it is easier to reproduce images.
- Automated presentation  
With a given range of context information, presentations such as slide shows or albums, can be automatically created. Context information can be used to select visualization schemes, suggest background audio, and to group images.
- Fun and augmented presentation  
Photos of activities, where the person taking the photos was involved, can be enhanced with additional information. This seems especially interesting with regard to sports.

We intentionally did not look at automating the process of initiating capture, as investigated in [3]. In none of our interviews or questionnaires people raised interest in automating the actual process of taking the picture. Helping to make better pictures (e.g. automatically setting the camera right) is a central concern to people, but one of the important points in photography is that the *user is in charge of the decision when to take the photo*.

The feedback we got showed a potential for several interesting domains even with simple sensing technologies. However, our overall impression was that it is necessary to design a prototype that allows collecting real context information to judge its value.

## 2.4 Specific Sensors of Interest

We asked people to rate their interest in different sensor information. At this point people had answered questions about meta information and usage of meta information and they were aware of the concept of context-aware photography. We presented the participants with a list of parameters that can be sensed and asked them to rate the importance of this

parameter. The importance could be assigned on a scale from 1 (useless) to 6 (very important). The following parameters were rated by at least 50% of the participants as useful or above (4, 5, or 6).

- Light conditions (74%)
- Acceleration (52%)
- Weather (51)
- Orientation (50%)

It was surprising to us that *location* in general was rated less important than the above. It is interesting to see that people would be as happy with town level location information as with precise location information for the purpose of meta data to digital photos.

Bio sensors, physiological sensors, temperature, and the detection of noise and smells were only considered useful by a minority of people.

Based on these findings we constructed a prototype that is described in the next section. We deliberately did not look into location information as this is available with cameras that include GPS (e.g. [1]) for precise location and with mobile phones that are using location based services on a coarse scale.

## 3. Prototype to Explore User Experience

To get more and in-depth feedback from users we built a prototypical system to record sensor data from various sources which can be seen in Figure 2.

### 3.1. Design and Concept

The overall system is designed as a tool to investigate the potential of using sensors of different types. First we considered using a PDA with a camera and a sensor board attached as a device to explore the user experience, similar as suggested in [6]. However, we realized that for ambitious hobbyists and professional photographers, using their own camera (or a model similar to their camera) is very important. Therefore the overall design consists of a sensor box that can be connected to the camera instead of a tripod or a flash. A notebook computer has been chosen as receiver for data sent by the sensor box that is connected to the camera. All sensor data is continuously streamed, time stamped and stored on the hard drive of the notebook computer. By synchronizing the clocks of the camera and on the notebook computer the sensor data can be matched to the photos.

### 3.2. Implementation of the Sensor Box

Reviewing the meta information of interest and having the wide range of possible contexts of interest in mind, we built a sensor box equipped with various sensors. The main sensor box is based on a Smart-Its module with a basic sensor board attached [2]. The basic Smart-Its includes a PIC18F452 microcontroller and a wireless transceiver (Radiometric SPM2-433-28). For our initial user trail it is equipped with the following sensors:

- Two 2-axes accelerometers, ADXL 202JE give information on the orientation of the camera.
- A magnetic compass module that is connected via I2C to the processor (CMPS03).
- Two light sensors provide information on the ambient light from different directions.
- A touch sensor, QT 110, is placed on the camera. It collects information when a specific part of the camera is touched. Amongst others, this can indicate how quick a shot was taken.
- A temperature sensor, Dallas DS 1621, that measures the temperature of the environment.

The software on the sensor box is written in C and continuously reads the sensors and transmits them wirelessly. The prototype fits into a small box, similar in size as an extra battery pack, and can be attached to the tripod mount at the bottom of the camera. This enabled the users to attach the prototype to a camera and work as they did before.

The basic hardware architecture of the sensor box is presented in Figure 1. The prototype of the sensor box is depicted in Figure 2.

Similar sensors have been explored in other research, e.g. [6], [7], with a focus on handheld devices. Additionally we used the sensor information provided by the camera, e.g. distance.

### 3.3. Receiver and Storage

To keep the sensor box small we decided to have the storage in a separate unit that is wirelessly connected. As receiver we used a notebook computer that was equipped with a receiver for the wireless signal using a Radiometrix SPM2 module connected to a serial line using a Serial to USB adapter. The computer with the receiver was placed in a backpack that was carried by the observer in the study. In Figure 3 the observer with the receiver and the photographer are shown.

On the computer runs a program that continuously reads from serial line and stores all incoming data in a

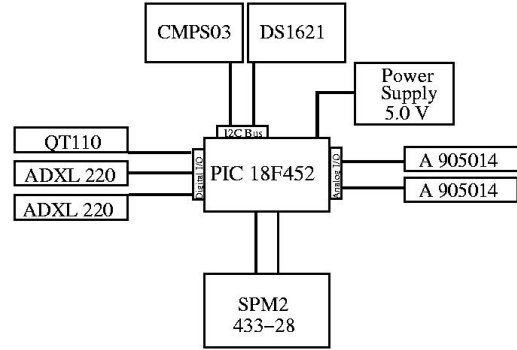

Figure 1: The hardware architecture of the sensor box to be attached to the camera.

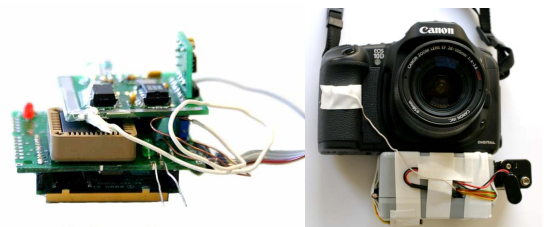

Figure 2: Hardware of the sensor box (left) and attached to a camera (right).

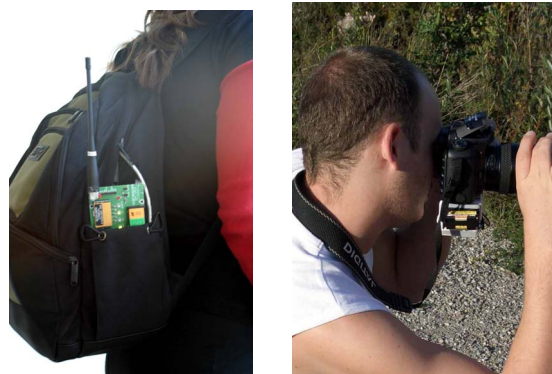

Figure 3: Observer with receiver and tablet pc in a backpack (left); photographer with our digital camera, including our prototype (right).

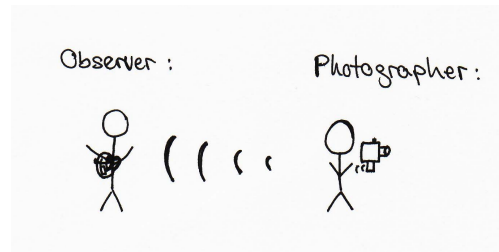

Figure 4: Sketch of setup. Meta information is sent from the camera to a close-by observer equipped with a laptop for later processing.

file. To each line of sensor readings a time stamp is added.

The problem of time synchronization between the clock of the camera and the one of the laptop could be solved as follows: Incoming sensor data is displayed on the laptop display. The current time of the laptop clock is shown next to it. Using the sensor enhanced camera, a photo is taken of this display. After the photo session, we can calculate the difference between the two clocks. The idea is similar to the clapper board in film production to synchronize audio and video.

The matching between sensor data and images is done separately when the pictures are downloaded from the camera. A Perl script is used to correctly adjust the sensor time stamps. In this step, we also connect the EXIF data of the photo with our sensor data. We used this setup throughout the study described in the next section.

#### 4. Users Explore the Prototype – A Study

The user study was designed to evaluate the prototype in a realistic setting. In addition to collecting sensor information we observed the photographers when taking pictures.

##### 4.1. Participants and Setup

For our study we recruited five individuals that expressed an interest in digital photography. All participants had been using a digital camera before. Three of them are photographers running their own studios and have at least ten years of professional experience in different areas of photography. Two participants are hobbyists and know only the basic concepts of digital photography.

The basic approach in the study was to have participants taking photos as they normally would do and continuously record sensor data at the same time. We gave participants a very brief introduction (about three minutes) to what the sensor box attached to the camera is recording. Then we asked them to take

**Table 1: Participants spend different time exploring the prototype resulting in a diverse set of photos with meta information attached.**

Participant	No of pictures	Time (min)	Conditions
Professional 1	69	114	Buildings; Indoors
Professional 2	10	5	Landscape
Professional 3	56	54	Night; Portrait, Outdoors
Amateur 1	51	82	Nature; Outdoors
Amateur 2	168	98	Landscape; Nature

photos in whatever way they wanted. There were no



**Figure 5: Picture taken with a digital camera including the sensor box. Figure 6 shows the meta information of our sensors, before, during and after the picture was taken.**

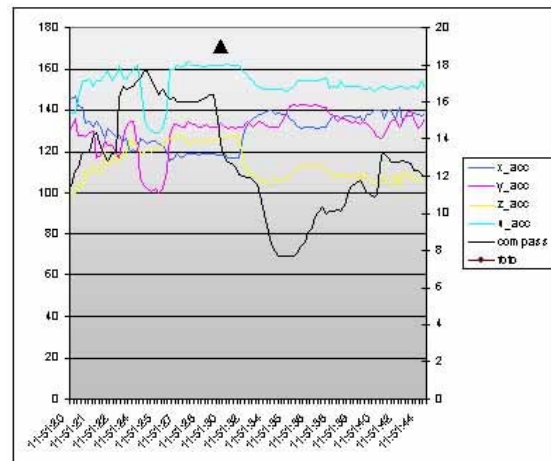

**Figure 6: Chart with sensor data, before, during and after the picture seen in Figure 5 was taken. The figure shows the values of four accelerometers and the compass.**

guidelines predefined, the participants chose individually when to go for a photo session, how long they used it, how many pictures they took, and where they used it. The observer shadowed the participants during the whole time they were using the enhanced camera, see Figures 3 and 4. Since the wireless transmission of data between camera and observer could easily be done even with some dozen meters distance, the photographer had complete freedom in his or her movements and was not disturbed in any fashion by the recording.

Table 1 shows the summary of the individual sessions. A total of 354 photos were taken and the participants used the prototype approximately 353 minutes in different settings, mainly outdoors. Time stamped sensor data was recorded for all participants

over the entire time of the study. Participants did not report that the attached prototype was limiting the way they could use the camera. This was also due to the light weight of the sensor box which is negligible in comparison to the weight of a professional camera.

## 4.2. Initial Results of the Study

Given the varying conditions and the individuals using the prototype we acquired a rich set of meta information.

From our first analysis of the sensor data, we can see that the handling of the camera before, during and after taking a picture can be isolated and shows interesting patterns. It can be determined when the camera is held steady in a certain posture by the photographer (and it can also be seen how steady the camera is hold). Figure 5 shows a picture taken by a professional photographer and Figure 6 shows the related sensor data. The black triangle marks the moment when the shot is taken. This point in time has been detected by a sensor attached close to the trigger and has been verified by analyzing the EXIF data.

The data plot shows that the photographer has reacted very quickly and has not pointed to the motive by steadily holding the camera, to configure it. The rotation he made to follow the fast movements of the pedestrian and the dog can be seen in the sudden change in the compass values (black thick line in the diagram). When analyzing the data further it can be observed that he moved the camera along with the motive, took the picture and put the camera down afterwards.

Our initial analysis of the collected meta data shows that there are potential improvements in several areas:

- Improving camera controls based on sensed actions and gesture, e.g. switching the display on when looking at the photo after a shot was taken.
- Determine the type of user and the environment in which the camera is used. This could be the basis for adjusting parameters and settings.
- Providing tips and hints to photographers by comparing the handling of the camera between amateurs and professionals.

## 5. Related Work

Using contextual information to trigger capture is an approach that has been explored in Startle Cam [3]. The hardware of this system consists of a wearable computer and video camera, and sensors attached to the user. The camera can be implicitly controlled by physiological parameters of the user. E.g. it can be set to takes pictures when the user is excited.

In the Sense Cam Project [4], a camera that automatically takes pictures is suggested as well. The hardware is a camera with sensors that is worn like a badge. Based on stimuli of sensors, still images are automatically taken. Typical triggers are changes in movement and changes in the ambient light level. The idea in this project is that by taking many pictures over the day (e.g. several thousands), those pictures may be helpful as a memory aid (e.g. “Where did I leave my phone?” or “Did I lock the front door?”).

In contrast to those we leave the control of when to take a photo completely to the user. Our initial study showed that the appeal of digital photography is to capture a certain motive at a certain time – and much of the creativity in people’s photos lies in those parameters. We aim at enhancing digital photography whereas SenseCam aims at creating a memory aid.

Integrating context information to digital photos for artistic purposes has been explored in a project at the Victoria Institute [5], [6]. Their prototype consists of a webcam and a set of sensors connected to a tablet pc (which functions as display). The user can take still images by pressing the shutter button. The actual image is displayed and effects related to sensor readings can be applied. Compared to our device they went for a PC approach, giving users a different feel than when using a digital camera. From our initial interviews we concluded that the camera itself has an important impact on how people take photos. Furthermore they only use the sensor information as additional parameters for changing images.

## 6. Conclusion and Further Work

Our initial findings suggest that additional information acquired by sensors enhances digital photography. Various contexts, such as the handling of the camera, environmental conditions, and social situation are of interest to the user. Additional meta information enables new application domains. With our prototype and study we showed that collecting meta information is feasible and can provide interesting data for further analysis.

Currently we are analyzing the data collected in more detail. Ours aims are to get ideas for new technical developments, understand what it takes a person to make good photos, and how to use meta data for augmented presentations.

## 7. Acknowledgement

The work has been conducted in the context of the research project Embedded Interaction (‘Eingebettete

Interaktion') and was funded by the DFG ('Deutsche Forschungsgemeinschaft').

## 8. References

- [1] Caplio Pro G3 with GPS receiver.  
<http://www.ricoh.com>, May 2004
- [2] WebHome Lancaster University. Smart-Its technical information. Wiki-Web  
<http://ubicomp.lancs.ac.uk/twiki/bin/viewauth/Smartits/>, August 2004
- [3] Healey, J. and Picard, R. W. StartleCam: A Cybernetic Wearable Camera. Proceedings of ISWC 1998, Perceptual Computing Technical Report Nr. 468 (1998).
- [4] SenseCam, <http://research.microsoft.com/hwsystems/>, August 2004
- [5] Håkansson, M., Ljungblad, S., Holmquist, L.E. Capturing the Invisible: Designing Context Aware Photography. Proceedings of DUX 2003.
- [6] Hinckley et al. "Sensing Techniques for Mobile Interaction", UIST 2000
- [7] Schmidt, A. European Project 'Technology for Enabling Awareness', HUC 1999
- [8] Context Photography, Victoria Institute  
<http://www.viktoria.se/fal/projects/photo/context.html>, August 2004
- [9] Gellersen H., Kortuem G., Schmidt A., Beigl M. Physical Prototyping with Smart-Its. IEEE Pervasive Computing Magazin, pp.12-18, July-Sept 2004
- [10] EXIF, <http://www.exif.org.>, August 2004